

baby food processing line

Model: BAB line



Baby food (Doypack) technological line consists of two professional equipment: Vacuum cutter ProfiCut and a filler/capper for spouted Doypack pouches.



baby food processing line

Model: BAB line



ProfiCut is a complete and versatile work tool that cooks, concentrates, kneads, refines, cuts, mixes, homogenises, pulverises various types of food products.



The filling line works by means of a Doselite pneumatic volumetric pump, with an adjustable dosage range between 5 and 1300 ml. The pouch is closed by means of a plastic screw cap.



Vacuum Cutter ProfiCut

ProfiCut is a universal plant for manufacturing a wide range of products. All operations are performed sequentially in a single plant starting from raw materials input to the finished product unloading. Grinding, mixing, and heating are applied under the vacuum to prevent oxidation, reduce the temperature of the product, thus retaining its taste and flavor and giving it an attractive appearance.

Filling and capping machine for spouted doypack

An automatic filling and capping line for the filling and capping of flexible doypack type bags (with already existing spout) with liquid and semi-liquid products. All parts of the machine in contact with the product are made of 316L stainless steel, PTFE and FKM gaskets.

The filling and capping station has an access door on both the front and rear of the structure. The machine is completed with an automatic plug-in power supply.

baby food processing line

Model: BAB line

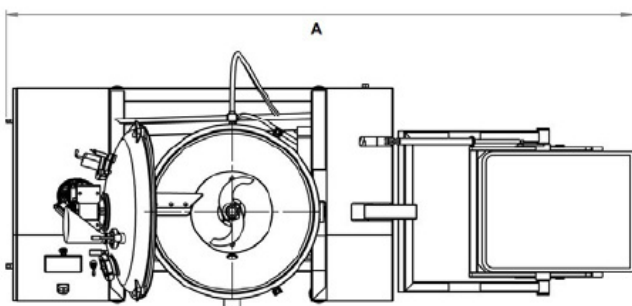
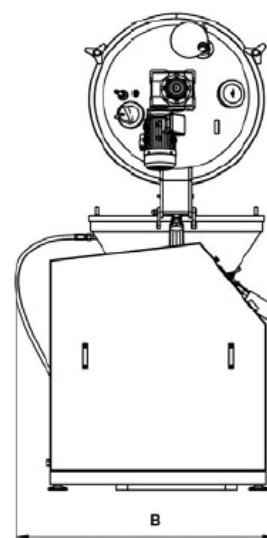
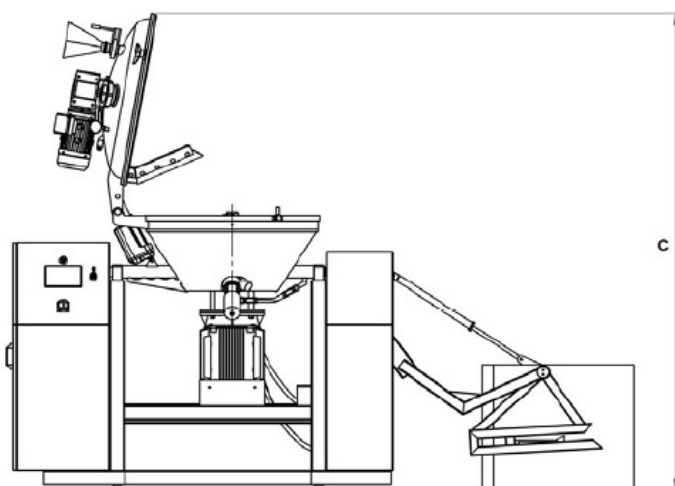
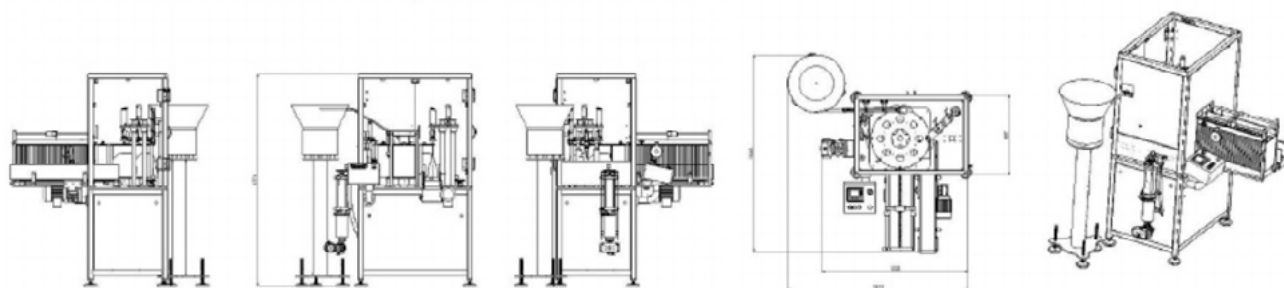

Geometric volume, L	130
A: length, mm	3 442
B: width, mm	1 416
C: height, mm	2 617

NORMIT FOOD, s. r. o.
Pezinská cesta 5104
901 01 Malacky, SLOVAKIA

Skype:
manager.normit

Telephone number:
+421 902 400 321

E-mail:
sales@normit.com

Web:
www.normit.com